

Innovating the Future of RV POWER

EM-15 & EM-20 | ENERGY MANAGEMENT SWITCH

More POWER for the RV Lifestyle

Model EM-15 - Output: 15A - Input: 120V AC, 60 Hz
Model EM-20 - Output: 20A - Input: 120 V AC, 60 Hz



Reliability. Vertically integrated, WFCO has total supply chain control, ensuring quality materials, parts and processes at each stage. Components are quality tested at critical manufacturing stages.

As RV designs get more and more like home life, so does the demand on their electrical infrastructure. RVers want to enjoy the comforts and luxuries at home while on the road, and with this in mind, WFCO has developed the cost-efficient EM-20 Energy Management Series switches.

- EM-15 for 15A applications
- EM-20 for 20A applications

PRODUCT FEATURES

- Smart Load Detection allows the device to switch from two power loads to one load (the designated priority load) when the total current exceeds a pre-determined trip level based on the model.
- The EM-20 can eliminate the need for 50 A service with two air conditioners by operating one at a time.
- Designed to manage two mid to heavy loads, such as microwaves and fireplace/water heaters, the EM-15 seamlessly switches power between appliances.
- The Energy Management Series Switches feature three possible mounting positions for flexible design and quick installation: wall/ floor mount, back of WF-8500 Power Center Series power center, or back of 8900 Series power center.



These features provide more safety and ease to technicians and RV owners.



Remote control panel, available with the EM-20 so end-users can manually choose the branch circuit with priority operation.

EASY INSTALLATION

All WFCO products meet RV owners' needs better while making the job more straightforward for the installer and production line. Both the EM-15 & EM-20 offer flexible mounting options. At the same time, the EM-20 also provides several unique features – like a remote panel for manual energy management and four power modes – that make it easy for RV owners to assign energy to the circuit they need.



The EM-20 allows a simple remote control hook up for convenient end-user power management.

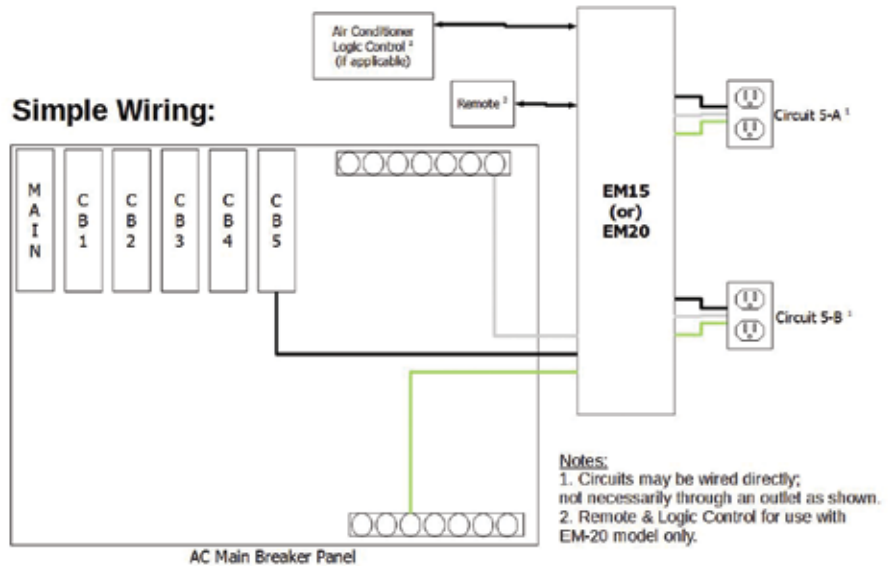

ENERGY MANAGEMENT SWITCH

| SPECIFICATIONS | EM-15 | EM-20 |
|----------------------|---|---|
| Power | 120 V / 60 Hz | |
| Power Relay | 2; Contact Rating: 30A/250 V AC; Coil Rating: 12 V DC | |
| Logic Control Rating | 2; SPDT Contact Rating: 3 A/250 V AC; Coil Rating: 12 V DC | |
| AC Connections | 9P terminal block for 14 AWG wire; suggested 7 in-lbs torque | 9p terminal block for 12 AWG wire; suggested 7 in-lbs torque |
| Remote Switch | | 12 ft. long wire and RJ11 connector; one switch to set circuit priority; 2 LEDs to indicate which circuit is priority |
| MECHANICAL | | |
| Enclosure | Fire-retardant reinforced plastic | |
| Mounting | Wall/floor mounting or mount directly to the back of WFCO Power Centers (WF-8900 or WF-8500 Series) | |
| Dimensions | Enclosure: 4 1/4"W x 5"L x 2 3/4"H / With Wall Mount: 4 7/16"W x 6 1/2"L x 3"H | |
| Weight | 0.55 kgs / 1.21 lb | |
| Safety | CETL / UL 916 + CSA C22.2 NO. 205 | |

Certifications: UL® and cUL® listed and FCC Class B compliant. Specifications are subject to change without notice or obligation. Case Material: Plastic, Color: Black



Our Power Pros provide expert technical support for everything the RV industry needs.

Visit wfcoelectronics.com/support.