

Product Manual



WF-8900-AD-REP SERIES CONVERTER REPLACEMENT KIT



• 2021 Aeroplex Drive, NorthElkhart, IN 46514 • (574)-294-8997 • www.wfcotech.com

TABLE OF CONTENTS

<u>SAFETY INFORMATION</u>	1
<u>GENERAL INFORMATION</u>	
Reverse Battery Protection.....	1
Blown Fuse Indicators	2
Automatic Cooling Fan	2
AC Voltage Indicators	2
Over-Temperature Protection	2
Electronic Current Limiting	2
Short Circuit Protection	2
<u>CIRCUIT PROTECTION</u>	
DC Fuses	3
AC Circuit Breaker	3
UL-Listed Main Circuit Breaker List.....	4
UL-Listed Branch Circuit Breaker List.....	4
<u>OPERATIONAL FEATURES</u>	
Auto Detect	5-7
<u>TROUBLESHOOTING INSTRUCTIONS</u>	
Converter Output Voltage	8-9
<u>GENERAL COMPLIANCE INFORMATION</u>	
Agency Listings.....	9
<u>INSTALLATION INSTRUCTIONS</u>	
Mounting the Enclosure.....	10-12
<u>SPECIFICATIONS</u>	12
<u>WARRANTY INFORMATION</u>	13-15

 **WARNING**

RISK OF ELECTRICAL SHOCK

Disconnect and isolate all power supplies before making electrical connections. More than one disconnection or isolation may be required to completely de-energize equipment. Contact with components carrying hazardous voltage can cause electric shock and may result in severe personal injury or death.

 **NOTICE**

All wiring must conform to local, national and regional codes and regulations. Use copper conductors ONLY for all wire connections. Do not exceed the electrical ratings for the WF-8900-AD Series Power center or the equipment connected to it. Failure to follow these precautions may cause permanent failure and/or electrical shock which could result in severe personal injury or death.

 **CAUTION**

EQUIPMENT SERVICING

This product should be installed by an experienced and certified technician. CAUTION and care must be taken when servicing this equipment. To prevent severe shock or electrocution, consult your servicing dealer.

 **WARNING**

SPARK HAZARD

This unit employs components that can produce arcs or sparks. To prevent fire or explosion, do not install in compartments containing batteries or flammable materials (i.e. gas). This product is NOT ignition protected.

 **CAUTION**

DO NOT OBSTRUCT VENTILATION

To prevent fire, do not cover or obstruct front cover ventilation openings as overheating may result. This series is a zero-clearance design, and as such, the only means of ventilation is through the front cover openings.

 **WARNING**

BATTERY SYSTEM

Use converter only on appropriate battery systems. Other usage may cause personal injury and damage. Consult all battery manufacturer's recommendations for additional safety information before use.

GENERAL INFORMATION

WF-8900-AD-REP Kit Features

The WF-8900-AD-REP Converter Replacement Kit allows easy upgrade of existing power centers. Technicians can easily remove the lower section of certain power center brands and slide in the WF-8900-AD-REP unit. This exchange upgrades the old single stage charger to a high performance three-stage charging powerhouse.

The WF-8900-AD-REP Kit contains all the necessary parts needed for the conversion:

- Metal mounting frame with preinstalled WF-9800-AD Series deck mount converter/charger
- Nine-circuit fuse panel with two preinstalled reverse polarity fuses
- All required mounting fasteners

OPERATIONAL FEATURES

WF-8900-AD-REP Performance Features

The WF-8900-AD-REP Converter Replacement Kit provides all WFCO's performance standards:

- Quiet Operation
- Filtered Power
- Overload Protection
- Short Circuit Protection
- FCC Class B Approval

INSTALLATION INSTRUCTIONS

Installing the WF-8900-AD-REP Kit

TOOLS NEEDED FOR ASSEMBLY

- Safety Glasses
- Large and Small Straight Blade Screwdriver
- #2 Phillips Screwdriver
- #2 Square Drive Screwdriver
- Pliers
- 1/4" Nutdriver
- 5/16" Nutdriver

STEP-BY-STEP INSTALLATION

Before beginning installation, make sure no AC power is coming into the RV from either the Shore Power cord or an on-board generator. Remove and set aside the Reverse Polarity Fuses located on the fuse board to disconnect the converter section from the rest of the RV's DC power.

WARNING

RISK OF ELECTRICAL SHOCK

Disconnect or isolate all power supplies before making electrical connections. More than one disconnection or isolation may be required to completely de-energize equipment. Contact with components carrying hazardous voltage can cause electric shock and may result in severe personal injury or death.

In order to install the WF-8900-AD-REP Kit, you must first remove the existing converter section in your power center. This kit can be used on several different products. Your power center may differ slightly in the removal process.

REMOVING THE ORIGINAL CONVERTER SECTION

Removal of the original power center is divided into 3 segments:

- Removing the AC (110 volt) side of the converter
- Removing the DC (12 volt) side of the converter
- Removing the converter MBA (Main Board Assembly)

REMOVING THE AC (110 VOLT) SIDE OF THE CONVERTER

1. Drop the front door down and turn off 30amp main breaker.
2. Remove all screws holding the front door assembly on.
3. Remove two screws holding the metal plate that covers the AC breakers.
4. Remove the converter neutral wire (white wire) from the neutral bus bar.
5. Remove the converter ground wire (green wire) from the ground bus bar.

Note: some converters may not have ground wire attached to the bus bar.

6. Remove the converter hot wire (black wire) from the breaker provided for the converter.

Note: sometimes removing the breaker from the stab bar may make this step easier.

Removing the DC (12 volt) side of the converter:

7. Record the fuse locations and wire locations off the old fuse board.
8. Remove all the output circuit wires from the fuse board.
9. Remove the two screws that hold the fuse board to the converter mounting bracket.
10. Turn the fuse board over to the back side and remove the red wire, white wire and blue wire from the fuse board.

REMOVING THE CONVERTER MBA

11. Remove the (four) screws holding the converter (MBA) frame to the housing.
12. Slide the converter MBA and frame out of the housing.

Note: The new WF-8900-AD-REP comes with a new fuse board and hardware package.

INSTALLATION OF THE WF-8900-AD-REP IS DIVIDED INTO THREE SEGMENTS

- Installing new converter (MBA) into housing.
- Installing the DC (12 volt) side of the converter
- Installing the AC (110 volt) side of the converter

INSTALLING NEW CONVERTER (MBA) INTO HOUSING

1. Position the new converter and frame in front of housing and remove the two screws that hold the converter to the frame (this makes routing the wires easier).
2. Carefully install the frame and converter into the housing and route wires from the converter through the holes in the frame and the housing.
3. Once all wires are routed correctly replace the two screws that hold the converter to the frame.
4. Attach the frame to the housing using the (four) screws provided.

THE WF-8900-AD-REP DC FUSE BOARD

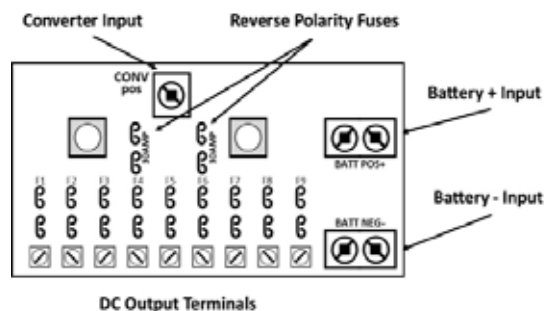

INSTALLING THE DC (12 VOLT) SIDE OF THE CONVERTER. REFER TO FIGURE 1 ON PREVIOUS PAGE

5. Route the red wire from the converter up behind the mounting bracket for the fuse board and connect it to the lug on the fuse board marked CONV POS.
6. Route the white wire from the converter to the fuse board and connect it to the lug on the fuse board marked BATT NEG-.
7. Connect your wire coming from the battery positive to the lug on the fuse board marked BATTERY POS+.
8. Connect your wire coming from the battery negative to the lug on the fuse board marked BATT NEG-. NOTE: In some applications where the items in the RV are not grounded to frame you may have to run an 8 AWG wire from the BATT NEG- lug on the fuse board out the back of the housing and connect it to an additional bus bar (customer will have to purchase). Then connect the wire from the battery negative and any negatives from the DC items to this bus bar.
9. Attach the fuse board to the mounting bracket using the two screws provided.
10. Make sure you have the two 30-amp reverse polarity fuses in place and connect all the DC output wire (as recorded) to the fuse board along with the correct fuse locations.

INSTALLING THE AC (110 VOLT) SIDE OF THE CONVERTER

11. Connect the neutral (white wire) from the converter to the neutral bus bar.
12. Connect the converter hot wire (black wire) from the converter to the breaker for the converter.
13. Connect the ground wire (green wire) from the converter to the ground bus bar.
14. Replace AC cover plate using the two screws provided.
15. Replace the door assembly using the screws provided.
16. Turn all breaker on and apply 110volt power to the RV. Test for operation.

TROUBLESHOOTING INSTRUCTIONS FOR THE WF-8900-AD-REP SERIES

Refer to the WF-8900-AD-REP Converter Replacement Kit Troubleshooting Guide is found on Page

SAFETY & PROTECTION FEATURES

REVERSE BATTERY HOOKUP PROTECTION

The WF-8900-AD-REP Converter Replacement Kit will charge the 12-volt house battery if installed. When a battery is installed, two reverse polarity fuses are installed to protect the converter circuitry. The fuses are located on the rear panel of the enclosure near the AC power cord (refer to Figure 2 below). This feature prevents permanent damage to the converter from a battery connected into the circuit backwards. In addition to protecting the converter-charger, the reverse polarity fuses are the main connection between the converter-charger and the DC fuse board of a distribution center. A battery does not have to be installed for WF-8900-AD-REP Converter Replacement Kit operation.

AUTOMATIC COOLING FAN

The cooling fan in the WF-8900-AD-REP Converter Replacement Kit is incremental and is controlled by the current drawn out of the converter to the applied load. The on-board microprocessor increases fan speed as the total load increases and decreases fan speed as the load decreases.

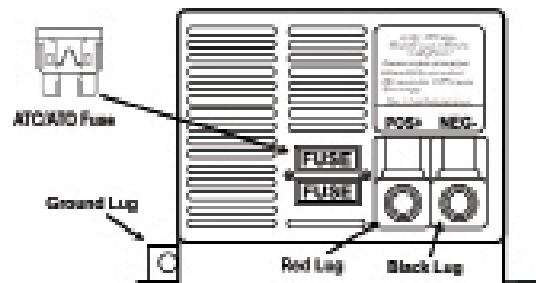

Unlike traditional temperature-controlled fans, the load-controlled fan provides better component cooling by avoiding temperature spikes which can lead to premature component failure.

OVER-TEMPERATURE PROTECTION

If the internal temperature of the converter exceeds a critical point, it will shut down. This protects the unit from excessive heat that may damage sensitive components. The unit will restart once the temperature inside has dropped.

ELECTRONIC CURRENT LIMITING

If the output current exceeds the maximum rating for the WF-8900-AD-REP Converter Replacement Kit, the output current will remain constant, but the output voltage will begin to drop. If this occurs, the unit will recover once loads are reduced.

SHORT-CIRCUIT PROTECTION

Should a short circuit occur in the RV, the WF-8900-AD-REP Converter Replacement Kit will drop the voltage output to zero volts. If the short-circuit condition is removed and no other fault conditions are detected, the converter will resume normal operation. However, short-circuit conditions are dangerous, and an RV will require inspection by a qualified service technician.

DC FUSES (12 VOLTS)

The DC fuse receptacle on the rear panel of the WF-8900-AD-REP Converter Replacement Kit has space for one or two Reverse Battery Protection fuses (see above). These fuses should be replaced with ATC or ATO automotive type fuses, such as Littelfuse type 257 or Bussmann type ATC. Each converter model requires a different Amperage value fuse as follows:

- WF-9835-AD – (1) 40A
- WF-9845-AD – (2) 30A
- WF-9855-AD – (2) 35A

OPERATIONAL FEATURES



AUTO-DETECT

This product includes the exclusive “Auto-Detect” feature for the charging of batteries. With this new technology, the power converter will evaluate the charging cycle of a battery, determine the type of battery being used, and then choose the appropriate charging program (profile) to provide for the best performance and maintenance of that battery. Because of the differences between Lead Acid, AGM and Lithium type batteries, a system that provides a charge to the battery or batteries must be able to accommodate the different charging requirements. With the use of the “Auto-Detect” product, the charging requirement can be “detected” and is then automatically set for the type of battery being used. For standard Lead Acid and AGM batteries, WFCO power converters still use the Three-Stage Smart Charging to effectively maximize battery life by monitoring through the different phases of the charge cycle. On the other hand, Lithium batteries will prefer the use of only two stages when charging, and therefore the power converter will charge using the WFCO Two-Stage Smart Charging system. NOTE: Regardless of charge profile (lead-acid or lithium), your battery is safe from harm and will still charge.

LED INDICATORS

WFCO converters have integrated LEDs which inform the user on which mode it is in. As it pertains to charging profiles, green is intended for the lead-acid charge profile while blue is intended for the lithium charge profile. The most important light of them all for charging is red, which signals bulk charge mode. When it comes to charging time and performance, green and blue will have much less impact than the red (bulk charge) light. Whether in green or blue, the red light means the converter is fast charging your batteries.

LEAD ACID & AGM THREE-STAGE SMART CHARGING

To maximize battery life for lead acid and AGM batteries, it is best to charge batteries slowly, keep them topped of with a trickle-charge when the RV is not being used. The 3-Stage “smart” charger continuously measures the battery voltage output and regulates the amount of charge using three modes of operation: Power, Charge and Storage modes. All WFCO power converters have automatic three-stage switching power supplies. The converter senses which mode it needs to be in by checking the RV system voltage.

POWER MODE

The converter normally provides a constant target output voltage of 13.6 VDC (nominal) to power all the branch circuits. However, it is current-limited, and if the output (load) current reaches its maximum, the output voltage will drop as necessary to hold the converter’s maximum output current level (the Amperage rating) without exceeding it.

CHARGE MODE

If the output current reaches its maximum (normally caused by a discharged battery), this will cause the converter to go into Charge Mode, which means the target output voltage will change to 14.4 VDC and a timer will start. Although the converter is outputting 14.4 VDC, you will not be able to read that on a voltmeter due to the volt age-current relationship. As mentioned in the paragraph above, as load current increases, output voltage decreases. The actual output voltage will not rise until the load current is reduced, which happens naturally as the battery charges or if 12 VDC appliances are turned of. Charge Mode will be maintained until the current draw drops to approximately five Amps, or until the timer reaches four hours (whichever happens first). Then the target output voltage is changed back to 13.6 VDC for Power Mode. Lights that are powered from the output may change brightness slightly at that time. Note: For a detailed explanation of the charging modes, please refer to our publication “Theory of Operation”, document #AD TD-0001-0. 5

STORAGE MODE

The third mode of charging is what is called the “float” charge. This mode is designed to provide a “trickle charge” to the battery after the system observes no significant variations in current draw over a long period of time. When in Storage Mode, the voltage will reduce from 13.6V to 13.2V and supply the “trickle charge” which helps to preserve the life of the battery while keeping it charged and ready for use. A change in DC current will cause the converter to exit the mode and return to the Absorption mode and then to Bulk mode if required.

LITHIUM TWO-STAGE SMART CHARGING

The two-stage “smart” charger continuously measures the battery voltage output and regulates the amount of charge using two modes of operation: Charge and Power mode - TWO-STAGE CONVERTER VOLTAGE OUTPUT MODES:

CHARGE MODE

This mode is designed with two purposes in mind. First, to quickly restore the energy back into the battery. Second, to ensure the lithium cells inside the battery remain balanced. This is accomplished by boosting the output voltage to 14.6 VDC and allowing the maximum current to flow as required by the loads. The charge mode stage could last anywhere from one to four hours based on the battery and load current which is being used. For a full battery, the charge stage has a minimum time requirement of one hour, which allows the lithium cells inside the battery the time required to “balance”. For an empty battery, the charge stage has a maximum time requirement of four hours. If your application requires longer than four hours (such as a larger battery bank > 200 Ahr), a simple cycling of power will reset the timers. As the energy is restored into the battery, the DC system voltage will climb and the current from the converter will decrease. If the total amperage-draw from the converter reaches a preset point (within the one-to-four-hour timer), the converter is designed to drop out of charge mode.

POWER MODE

This mode is designed with 1 purpose in mind. This purpose is to provide a safe operating voltage for all loads in the RV. This is accomplished by reducing (from charge mode) the output voltage to 13.6 VDC and remaining at this voltage until the power is cycled to the converter. The power mode stage is the default or normal mode of operation, which has no timer associated with it. In this mode an output of 13.6 VDC is provided to the DC circuits in the RV. This voltage has a long-term history as the acceptable voltage for all loads in the RV, and should not place undue stress (nor reduce the longevity) of the lights and appliances in the RV. This is not to say that all loads will have an issue with a constant higher voltage; however, some loads may have an issue. Please refer to the individual manufacturer’s specifications for acceptable operating voltage range of the connected load.

CHARGING PERFORMANCE

There are many factors that can impact charging performance in charge mode regardless of battery type (some may impact Auto-Detect operation):

- Length and gauge of wire from battery to converter – Can result in voltage drop and current loss, significantly increasing charge time. (See voltage drop chart on the next page).

- Battery brand – Some lithium batteries have a higher operating voltage.
- Solar power installed without solar disconnect – This can cause competition during active charging and potentially disrupt both chargers.
- High current loads during bulk charge – Will extend the battery charge time due to reduced current available for charging. May also interfere with the Auto-Detect algorithm to trigger lithium mode.
- Converter size: A 55-amp converter can charge a battery faster than a 35-amp converter.

CHARGING PERFORMANCE

There are many factors that can impact charging performance in charge mode regardless of battery type (some may impact Auto-Detect operation):

- Length and gauge of wire from battery to converter can result in voltage drop and current loss, significantly increasing charge time. (See voltage drop chart below).
- Battery brand – some lithium batteries have a higher operating voltage. Solar power installed without solar disconnect – this can cause competition during active charging and potentially disrupt both chargers.
- High current loads during bulk charge: Will extend the battery charge time due to reduced current available for charging. May also interfere with the Auto-Detect algorithm to trigger lithium mode.
- Converter size: A 55-amp converter can charge a battery faster than a 35-amp converter.

The charging profile is not set in stone. WFCO Auto-Detect converters monitor the current over time at the end of every charge cycle. So, in the event of a misdetection due to external factors, once the factors are addressed or no longer present, the converter can still properly detect the battery type during the next charge cycle.

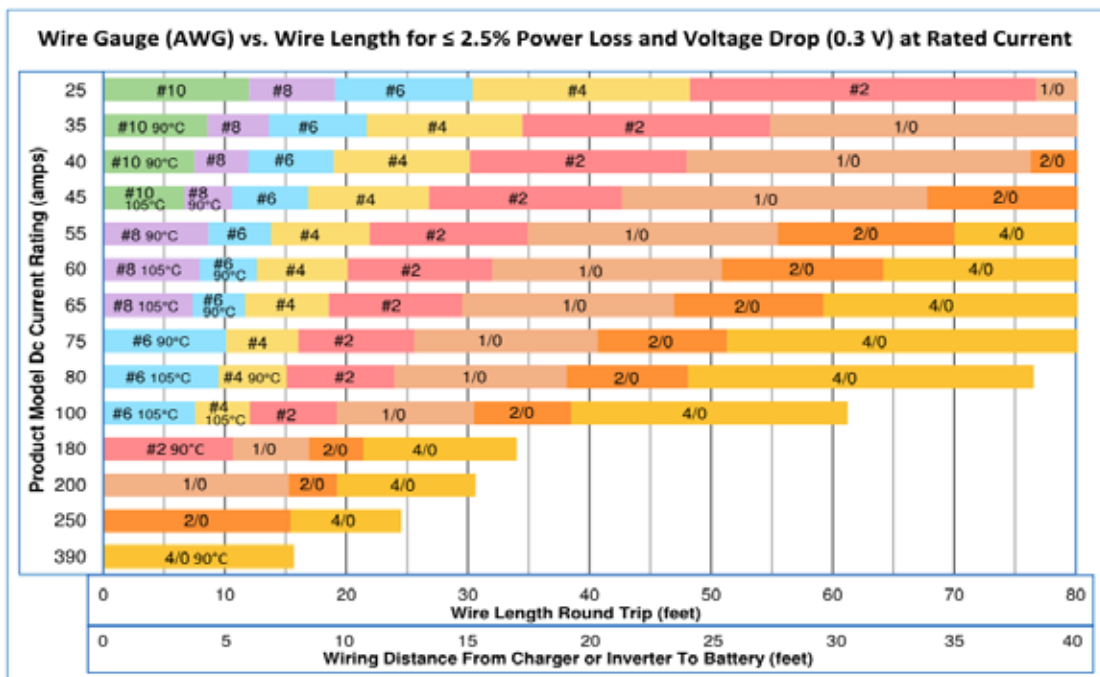

⚠ CAUTION

INSTALLATION AND SERVICING

This product should be installed and serviced by a certified or licensed electrician familiar with applicable safety codes and installation requirements. Failure to observe this precaution could result in electrical shock or bodily injury. Consult your servicing dealer before attempting any work on this product.

CHECKING CONVERTER OUTPUT VOLTAGE

Before checking the WF-8900-AD-REP Converter Replacement Kit output voltage, disconnect the battery cables at the battery. Make sure the converter is plugged into an AC source (105-130 Volts). Check the converter output voltage at the battery with a voltmeter. Place the meter probes on the disconnected battery cables; place the Positive (red) meter probe on the + Positive battery wire and place the Negative (black) meter probe on the -Negative wire on the battery cable (figure below). Be sure you have good connections at the cables. If the voltage reads 13.6 - 14.4V, the converter is functioning properly.

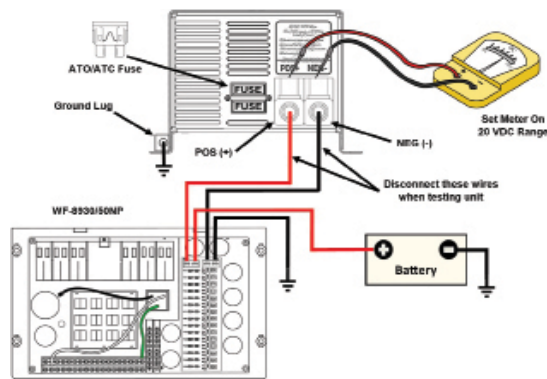

If the converter output voltage at the battery reads 0.0 VDC, or if the battery is not charging, check for an open inline fuse in the battery wire circuit. One may have been installed by the RV manufacturer. Also check for loose wiring connections.

CHECKING FOR REVERSE BATTERY HOOKUP (REVERSE POLARITY FUSES)

If there is no DC output coming from the WF-8900-AD-REP Converter Replacement Kit output lugs, first check the reverse polarity fuses on the rear panel. Then, visually inspect the fuses for any breaks in the fuse element. If no breaks are found, use a continuity tester to check for continuity. If the reverse polarity fuses are blown, it means the RV battery was accidentally connected in reverse, either at the battery or at the converter. Investigate the connections and reconnect the cables properly. Replace the fuse with the same type and amperage rating as the original.

IMPORTANT: These fuses protect the converter from damage if the RV battery is accidentally connected in reverse. A reversed battery connection, even if for only a second, will cause these fuses to blow.

If the above checks have been made but the converter output still reads 0.0 VDC, the converter is not functioning properly.

AC REVERSE POLARITY (AUDIBLE ALARM)

This power center is equipped with an AC REVERSE POLARITY PROTECTION feature. Should the incoming AC neutral wire and lead wire be connected backwards at the power center, an alarm located in the power center enclosure will sound. This alarm will continue to sound until the AC wires are connected correctly.

GENERAL COMPLIANCE

Agency Listings

UL

The WF-8900-AD-REP Converter Replacement Kit are UL-Listed, and cUL-Listed (Canadian).

FCC COMPLIANCE CLASS B

NOTE: This equipment has been tested and found to comply with the limits for a Class B digital device, pursuant to Part 15 of the FCC Rules. These limits are designed to provide reasonable protection against harmful interference when the equipment is operated in a commercial environment. This equipment generates, uses, and can radiate radio frequency energy, and if not installed and used in accordance with the instruction manual, may cause harmful interference to radio communications. Operation of this equipment in a residential area is likely to cause harmful interference in which case the user will be required to correct the interference at their own expense.

SPECIFICATIONS	WF-8935-AD-REP	WF-8945-AD-REP	WF-8955-AD-REP
Power Input	600 W	780 W	950 W
Input Voltage	105 V AC - 130 V AC / 60 Hz		
Output Current (LA/LI)	35 A / 32.5 A	45 A / 41.5 A	55 A / 50 A
Converter Type	3 Stage Converter Charger / 2 Stage Converter Charger		
Voltage Output	13.2 - 14.4 V DC / 13.6 14.6 V DC		
Normal mode	13.6 V DC		
Trickle charge mode (LA Only)	13.2 V DC		
Bulk charge mode	14.4 V DC / 14.6 V DC		
Kit Size:	11 7/8"W x 7 5/8"L x 5 3/4"H		
Outer Dimensions	13 1/4"W x 7 7/8"L x 5 1/4"H		
Fuse Board Dimensions	2 7/8"W x 7/8"L x 5 1/4"H		
Weight	6.75 lb	8 lb	9.25 lb

Certifications: UL® and cUL® listed and FCC Class B compliant.
Specifications are subject to change without notice or obligation.

CONSUMER LIMITED WARRANTY - FOR WFCO PRODUCTS

WFCO extends, to the original owner, a Two-Year Limited Product Warranty. This warranty is in effect from the date of original purchase for a period of two years. This limited warranty is extended specifically for and is limited to Recreational Vehicle application and is only valid within the continental United States, Alaska, Hawaii and the Provinces of Canada. WFCO warrants, to the owner, that its products are free from defects in material and workmanship under normal use and service based on its intended use and function. This warranty is limited to the repair or replacement, at WFCO's discretion, of any defective parts or defective assembly. Any implied warranties of merchantability or fitness for intended use are limited in duration unless applicable State Law provides otherwise. You may have other rights as specified by each individual state.

EXCLUSIONS AND LIMITATIONS

The OEM warranty specifically does not apply to the following:

- Any WFCO product that has been repaired or altered by an unauthorized person.
- Any damage caused by misuse, faulty installation, testing, negligence, accident or any WFCO product installed in a commercial vehicle.
- Any WFCO product, whose serial number has been defaced, altered or removed.
- Any WFCO product, whose installation has not been in accordance with the WFCO written instructions.
- Any consequential damages arising from the loss of use of the product including but not limited to inconvenience, loss of service, loss of revenue, loss or damage to personal property, cost of all services performed in removing or replacing the WFCO product. Specifications are subject to change without notice or obligation.
- Any WFCO Electronics products sold through unauthorized Internet sources (Example: eBay) will be excluded from all warranty coverage offered by WFCO Technologies.

CONSUMER WARRANTY CLAIM PROCEDURE

Upon determination and validation by an authorized OEM dealer that a WFCO product has a defect, a Return Goods Authorization (RGA) number will be required before the product can be returned. The RGA number can be requested by completing the Warranty Information Fax Sheet and appropriate Troubleshooting Form found at wfcotelectronics.com. Once these forms have been completed, email the forms along with Proof of Purchase to warranty@wfcotech.com or fax the three documents to the Warranty Department at (574) 294-8698. After receipt of the forms, an RGA number will be issued. This number shall appear on all correspondence with warranty service. Upon validation of the warranty, WFCO shall replace the product with a like product. The RGA number shall be placed on the outside of the carton used to return the product for ease of identification. Do not mark directly on the product. The product must be packaged properly to avoid further product damage which could cause a non-warrantable condition.

WARRANTY ASSISTANCE

The consumer may contact the selling Dealer or OEM for warranty assistance. The consumer may also contact WFCO Technologies at: (574) 294-8997 or Fax (574) 294-8698.

WF-8900-AD-REP DIMENSIONAL DRAWING

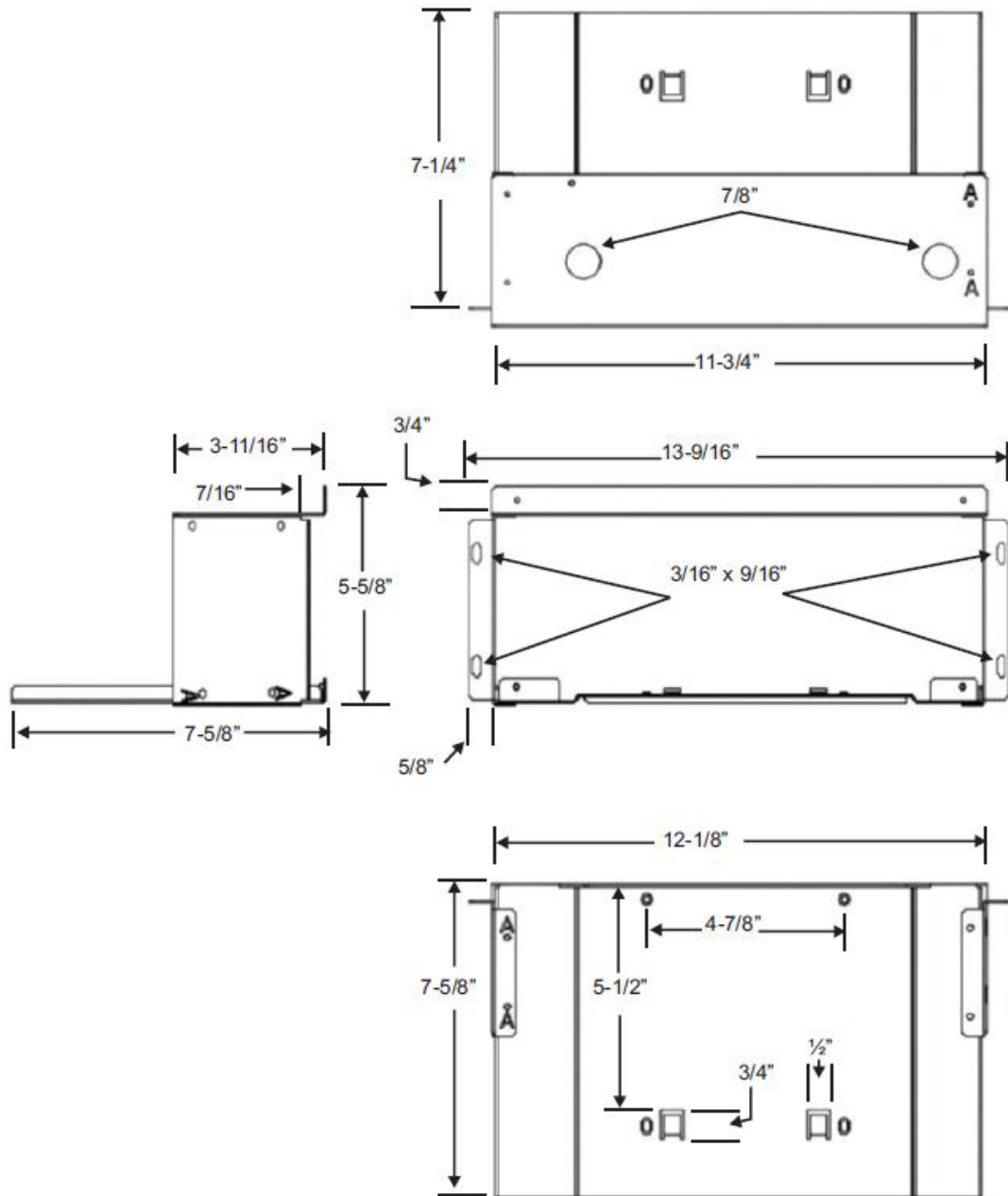

WFCO



TECHNOLOGIES

*Innovating the future of **RV POWER.***

2021 Aeroplex Drive, North
Elkhart, IN 46514
574-294-8997
www.wfcotech.com



Power Pros Technical Support
(574) 294-8997, Option 1
technicalsupport@wfcoelectronics.com

Warranty Information
Fax: (574) 294-8698
warranty@wfcoelectronics.com