

Product Manual



WF-68100-AD DECK MOUNT CONVERTER CHARGER



• 2021 Aeroplex Drive, NorthElkhart, IN 46514 • (574)-294-8997 • www.wfcotech.com

TABLE OF CONTENTS

<u>SAFETY INFORMATION</u>	1
<u>GENERAL INFORMATION</u>	
Reverse Battery Protection.....	1
Blown Fuse Indicators	2
Automatic Cooling Fan	2
AC Voltage Indicators	2
Over-Temperature Protection	2
Electronic Current Limiting	2
Short Circuit Protection	2
<u>CIRCUIT PROTECTION</u>	
DC Fuses	3
<u>OPERATIONAL FEATURES</u>	
Auto Detect	3-5
Three-Stage Smart Charging.....	5
Two-Stage Smart Charging	6
<u>TROUBLESHOOTING INSTRUCTIONS</u>	
Converter Output Voltage	6
Reverse Polarity Fuses	7
Troubleshooting Flow Chart.....	7
<u>GENERAL COMPLIANCE INFORMATION</u>	
Agency Listings.....	7
<u>INSTALLATION INSTRUCTIONS</u>	
Mounting the Enclosure.....	8
Wiring the AC Breakers.....	8
Wiring the DC Fuse Board	8
<u>SPECIFICATIONS</u>	9
<u>WARRANTY INFORMATION</u>	10-11

 **WARNING**

RISK OF ELECTRICAL SHOCK

Disconnect and isolate all power supplies before making electrical connections. More than one disconnection or isolation may be required to completely de-energize equipment. Contact with components carrying hazardous voltage can cause electric shock and may result in severe personal injury or death.

 **NOTICE**

All wiring must conform to local, national and regional codes and regulations. Use copper conductors ONLY for all wire connections. Do not exceed the electrical ratings for the WF-68100-AD Series Converter/Charger or the equipment connected to it. Failure to follow these precautions may cause permanent failure and/or electrical shock which could result in severe personal injury or death.

 **CAUTION**

EQUIPMENT SERVICING

This product should be installed by an experienced and certified technician. CAUTION and care must be taken when servicing this equipment. To prevent severe shock or electrocution, consult your servicing dealer.

 **WARNING**

SPARK HAZARD

This unit employs components that can produce arcs or sparks. To prevent fire or explosion, do not install in compartments containing batteries or flammable materials (i.e. gas). This product is NOT ignition protected.

 **CAUTION**

DO NOT OBSTRUCT VENTILATION

To prevent fire, do not cover or obstruct front cover ventilation openings as overheating may result. This series is a zero-clearance design, and as such, the only means of ventilation is through the front cover openings.

 **WARNING**

BATTERY SYSTEM

Use converter only on appropriate battery systems. Other usage may cause personal injury and damage. Consult all battery manufacturer's recommendations for additional safety information before use.

GENERAL INFORMATION

WF-68100-AD Series Converter/Charger Safety Features

REVERSE BATTERY PROTECTION

The WF-68100-AD Series Converter-Chargers will charge the 12-volt house battery if installed. A battery does not have to be installed for WF-68100-AD Series Converter-Charger's operation. When a battery is installed, three reverse polarity fuses are installed to protect the converter circuitry. The fuses are located on the rear panel of the enclosure near the AC power cord (Refer to Figure 1 on the following page). This feature prevents permanent damage to the converter from a battery connected into the circuit backwards. In addition to protecting the converter-charger, the reverse polarity fuses are the main connection between the converter-charger and the DC fuse board of a distribution center.

AUTOMATIC COOLING FAN

The cooling fan in the WF-68100-AD Series Converter-Chargers is 2-stage and is controlled by the current drawn out of the converter to the applied load. The on-board microprocessor increases fan speed as the total load increases and decreases fan speed as the load decreases. Unlike traditional temperature-controlled fans, the load-controlled fan provides better component cooling by avoiding temperature spikes which can lead to premature component failure.

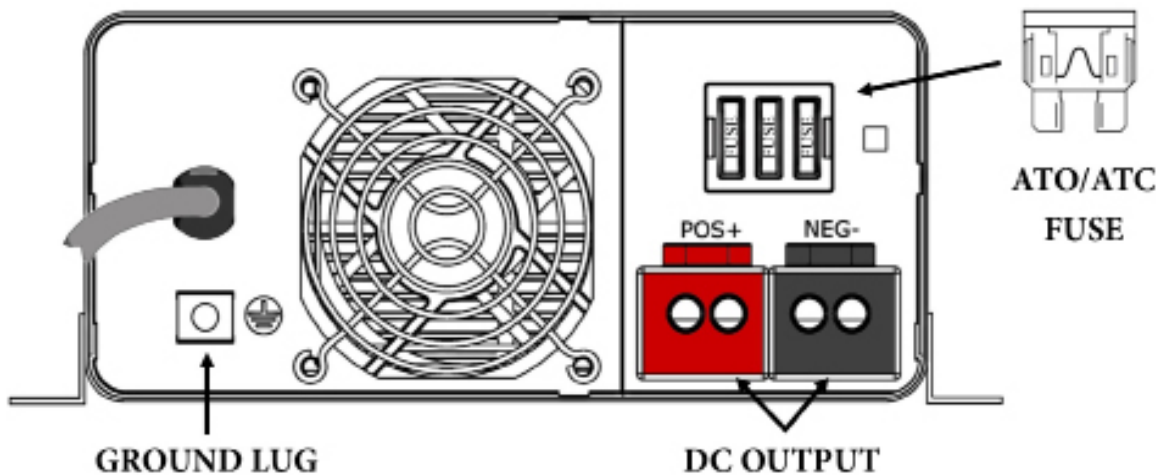

OVER-TEMPERATURE PROTECTION

If the internal temperature of the converter exceeds a critical point, it will shut down. This protects the unit from excessive heat that may damage sensitive components. The unit will restart once the temperature inside has dropped.

ELECTRONIC CURRENT LIMITING

If the output current exceeds the maximum rating for the WF-68100-AD Series Converter-Charger, the output current will remain constant, but the output voltage will begin to drop. If this occurs, the unit will recover once loads are reduced.

SHORT-CIRCUIT PROTECTION

Should a short circuit occur in the RV, the WF-68100-AD Series Converter-Charger will drop the voltage output to zero volts. If the short-circuit condition is removed and no other fault conditions are detected, the converter will resume normal operation. However, short-circuit conditions are dangerous, and an RV will require inspection by a qualified service technician.

CIRCUIT PROTECTION

WF-8900-AD Series Power Center Fuses and Breakers

DC FUSES (12 VOLTS)

The DC fuse receptacle on the rear panel of the WF-68100-AD Series Converter-Charger has space for 3 (three) identical Reverse Battery Protection fuses (see Figure 1 above). These fuses should be replaced with ATC or ATO automotive type fuses, such as Littelfuse type 257 or Bussmann type ATC. The fuses are 35 Amp.

OPERATIONAL FEATURES



AUTO-DETECT

This product includes the exclusive “Auto-Detect” feature for the charging of batteries. With this new technology, the power converter will evaluate the charging cycle of a battery, determine the type of battery being used, and then choose the appropriate charging program (profile) to provide for the best performance and maintenance of that battery. Because of the differences between Lead Acid, AGM and Lithium type batteries, a system that provides a charge to the battery or batteries must be able to accommodate the different charging requirements. With the use of the “Auto-Detect” product, the charging requirement can be “detected” and is then automatically set for the type of battery being used. For standard Lead Acid and AGM batteries, WFCO power converters still use the Three-Stage Smart Charging to effectively maximize battery life by monitoring through the different phases of the charge cycle. On the other hand, Lithium batteries will prefer the use of only two stages when charging, and therefore the power converter will charge using the WFCO Two-Stage Smart Charging system. NOTE: Regardless of charge profile (lead-acid or lithium), your battery is safe from harm and will still charge.

LED INDICATORS

WFCO converters have integrated LEDs which inform the user on which mode it is in. As it pertains to charging profiles, green is intended for the lead-acid charge profile while blue is intended for the lithium charge profile. The most important light of them all for charging is red, which signals bulk charge mode. When it comes to charging time and performance, green and blue will have much less impact than the red (bulk charge) light. Whether in green or blue, the red light means the converter is fast charging your batteries.

LEAD ACID & AGM THREE-STAGE SMART CHARGING

To maximize battery life for lead acid and AGM batteries, it is best to charge batteries slowly, keep them topped off with a trickle-charge when the RV is not being used. The 3-Stage “smart” charger continuously measures the battery voltage output and regulates the amount of charge using three modes of operation: Power, Charge and Storage modes. All WFCO power converters have automatic three-stage switching power supplies. The converter senses which mode it needs to be in by checking the RV system voltage.

POWER MODE

The converter normally provides a constant target output voltage of 13.6 VDC (nominal) to power all the branch circuits. However, it is current-limited, and if the output (load) current reaches its maximum, the output voltage will drop as necessary to hold the converter's maximum output current level (the Amperage rating) without exceeding it.

CHARGE MODE

If the output current reaches its maximum (normally caused by a discharged battery), this will cause the converter to go into Charge Mode, which means the target output voltage will change to 14.4 VDC and a timer will start. Although the converter is outputting 14.4 VDC, you will not be able to read that on a voltmeter due to the volt age-current relationship. As mentioned in the paragraph above, as load current increases, output voltage decreases. The actual output voltage will not rise until the load current is reduced, which happens naturally as the battery charges or if 12 VDC appliances are turned of. Charge Mode will be maintained until the current draw drops to approximately five Amps, or until the timer reaches four hours (whichever happens first). Then the target output voltage is changed back to 13.6 VDC for Power Mode. Lights that are powered from the output may change brightness slightly at that time. Note: For a detailed explanation of the charging modes, please refer to our publication “Theory of Operation”, document #AD TD-0001-0. 5

STORAGE MODE

The third mode of charging is what is called the “float” charge. This mode is designed to provide a “trickle charge” to the battery after the system observes no significant variations in current draw over a long period of time. When in Storage Mode, the voltage will reduce from 13.6V to 13.2V and supply the “trickle charge” which helps to preserve the life of the battery while keeping it charged and ready for use. A change in DC current will cause the converter to exit the mode and return to the Absorption mode and then to Bulk mode if required.

LITHIUM TWO-STAGE SMART CHARGING

The two-stage “smart” charger continuously measures the battery voltage output and regulates the amount of charge using two modes of operation: Charge and Power mode - TWO-STAGE
CONVERTER VOLTAGE OUTPUT MODES:

CHARGE MODE

This mode is designed with two purposes in mind. First, to quickly restore the energy back into the battery. Second, to ensure the lithium cells inside the battery remain balanced. This is accomplished by boosting the output voltage to 14.6 VDC and allowing the maximum current to flow as required by the loads. The charge mode stage could last anywhere from one to four hours based on the battery and load current which is being used. For a full battery, the charge stage has a minimum time requirement of one hour, which allows the lithium cells inside the battery the time required to “balance”. For an empty battery, the charge stage has a maximum time requirement of four hours. If your application requires longer than four hours (such as a larger battery bank > 200 Ahr), a simple cycling of power will reset the timers. As the energy is restored into the battery, the DC system voltage will climb and the current from the converter will decrease. If the total amperage-draw from the converter reaches a preset point (within the one-to-four-hour timer), the converter is designed to drop out of charge mode.

POWER MODE

This mode is designed with 1 purpose in mind. This purpose is to provide a safe operating voltage for all loads in the RV. This is accomplished by reducing (from charge mode) the output voltage to 13.6 VDC and remaining at this voltage until the power is cycled to the converter.

The power mode stage is the default or normal mode of operation, which has no timer associated with it. In this mode an output of 13.6 VDC is provided to the DC circuits in the RV. This voltage has a long-term history as the acceptable voltage for all loads in the RV, and should not place undue stress (nor reduce the longevity) of the lights and appliances in the RV. This is not to say that all loads will have an issue with a constant higher voltage; however, some loads may have an issue. Please refer to the individual manufacturer's specifications for acceptable operating voltage range of the connected load.

CHARGING PERFORMANCE

There are many factors that can impact charging performance in charge mode regardless of battery type (some may impact Auto-Detect operation):

- Length and gauge of wire from battery to converter – Can result in voltage drop and current loss, significantly increasing charge time. (See voltage drop chart below)
- Battery brand – Some lithium batteries have a higher operating voltage.
- Solar power installed without solar disconnect – This can cause competition during active charging and potentially disrupt both chargers.
- High current loads during bulk charge: Will extend the battery charge time due to reduced current available for charging. May also interfere with the Auto-Detect algorithm to trigger lithium mode.
- Converter size – A 55-amp converter can charge a battery faster than a 35-amp converter.

The charging profile is not set in stone. WFCO Auto-Detect converters monitor the current over time at the end of every charge cycle. So, in the event of a misdetection due to external factors, once the factors are addressed or no longer present, the converter can still properly detect the battery type during the next charge cycle.

Below is a guide to minimize voltage drop to 2.5% or less. This is a reference guide for optimized charging performance and does not take priority over code requirements.

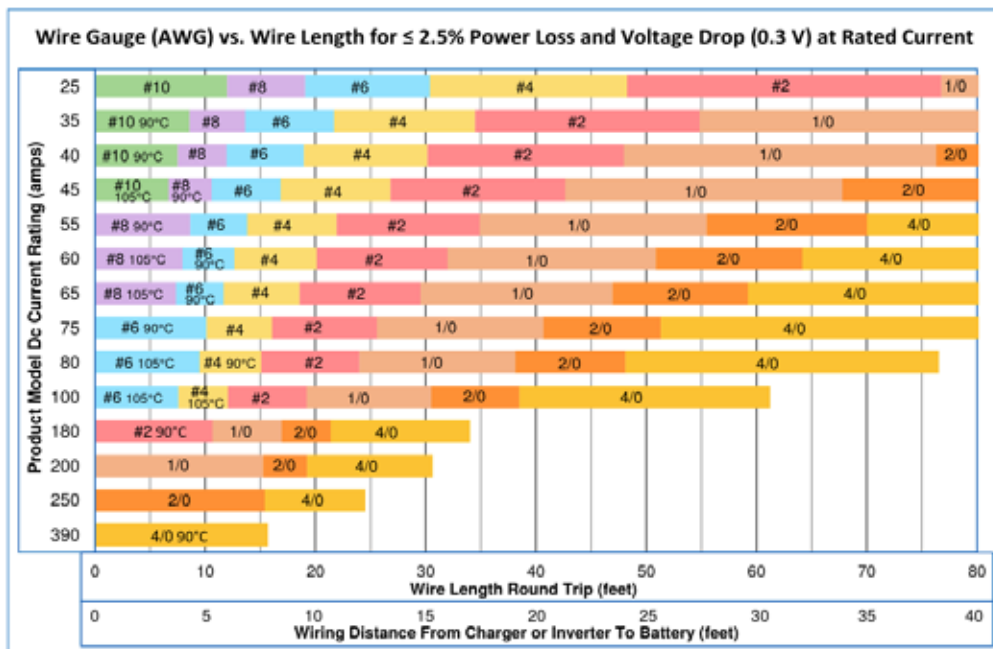

TROUBLE SHOOTING INSTRUCTIONS

Troubleshooting the WF-68100-AD Series Power Converter Charger

CAUTION

INSTALLATION AND SERVICING

This product should be installed and serviced by a certified or licensed electrician familiar with applicable safety codes and installation requirements. Failure to observe this precaution could result in electrical shock or bodily injury. Consult your servicing dealer before attempting any work on this product.

CHECKING CONVERTER OUTPUT VOLTAGE

Before checking the WF-68100-AD Series Converter-Charger output voltage, disconnect the battery cables at the battery. Make sure the converter is plugged into an AC source (105-130 Volts). Check the converter output voltage at the battery with a voltmeter. Place the meter probes on the disconnected battery cables; place the Positive (red) meter probe on the + Positive battery wire and place the Negative (black) meter probe on the - Negative wire on the battery cable.

Be sure you have good connections at the cables. If the voltage reads 13.6 - 14.6V, the converter is functioning properly. If the converter output voltage at the battery reads 0.0 VDC, or if the battery is not charging, check for an open inline fuse in the battery wire circuit. One may have been installed by the RV manufacturer. Also check for loose wiring connections.

REVERSE POLARITY FUSES

If there is no DC output coming from the WF-68100-AD Series Converter-Charger output lugs, first check the reverse polarity fuses on the rear panel. Then, visually inspect the fuses for any breaks in the fuse element. If no breaks are found, use a continuity tester to check for continuity. If the reverse polarity fuses are blown, it means the RV battery was accidentally connected in reverse, either at the battery or at the converter. Investigate the connections and reconnect the cables properly. Replace the fuse with the same type and amperage rating as the original.

IMPORTANT: These fuses protect the converter from damage if the RV battery is accidentally connected in reverse. A reversed battery connection, even if for only a second, will cause these fuses to blow.

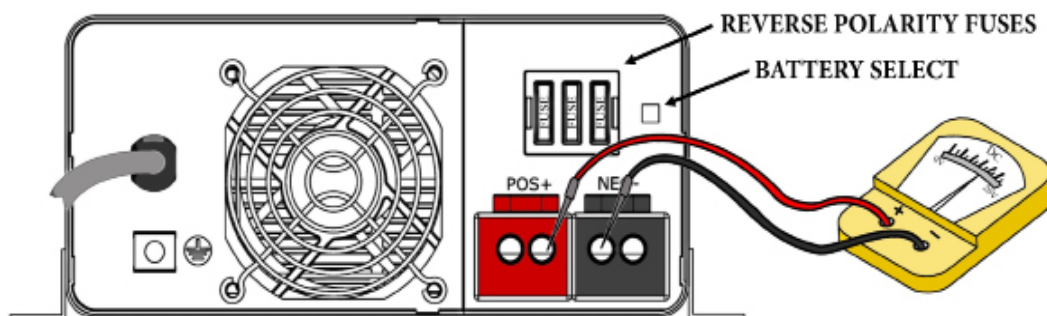

BATTERY SELECT SWITCH

The Battery Select switch is a two-position slide switch that selects either Lead Acid/AGM or Gel battery. In the Lead Acid/AGM position, the converter will output both Absorption and Bulk Mode voltages.

With the Battery Select switch in the GEL position, the output will remain in Absorption Mode. Bulk Mode is disabled to prevent damage to the GEL batteries.

If the above checks have been made but the converter output still reads 0.0 VDC, the converter is not functioning properly.

Troubleshooting Guide for the WF- 68100-AD Series Deck Mount

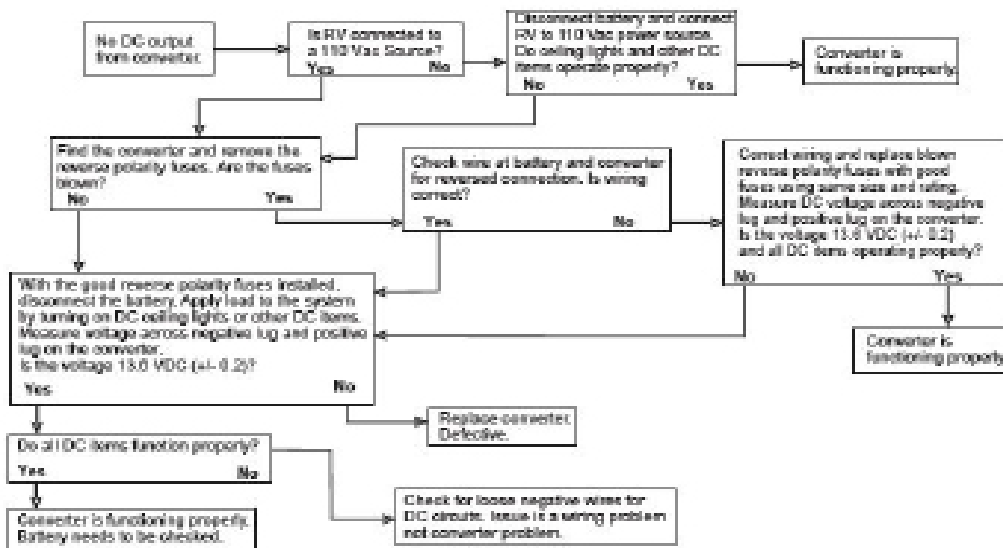

GENERAL COMPLIANCE INFORMATION

Agency Listings

UL

The WF-68100-AD Series Converter-Chargers are UL-Listed, and cUL-Listed (Canadian).

FCC COMPLIANCE CLASS B

NOTE: This equipment has been tested and found to comply with the limits for a Class B digital device, pursuant to Part 15 of the FCC Rules. These limits are designed to provide reasonable protection against harmful interference when the equipment is operated in a commercial environment. This equipment generates, uses, and can radiate radio frequency energy, and if not installed and used in accordance with the instruction manual, may cause harmful interference to radio communications. Operation of this equipment in a residential area is likely to cause harmful interference in which case the user will be required to correct the interference at their own expense.

INSTALLATION INSTRUCTIONS

Installing the WF-68100-AD Series Converter-Charger

MOUNTING THE ENCLOSURE

The WF-68100-AD Series Converter-Charger enclosure should be mounted in an accessible area such as a wall or in the side of a cabinet. Select a mounting location near the shore power and battery (batteries), in an area where the owner is unlikely to store items as this could reduce clearance requirements, obstruct ventilation openings and affect the performance of the converter. The location should be selected to prevent excessive heat, water, moisture, dust and dirt entering the unit installed. As a rule, allow a minimum of two cubic feet of clear airspace and or any additional venting as necessary to prevent the unit from overheating. The front of the enclosure should not be obstructed to allow free air flow for the cooling fan (see below).

An 8AWG copper conductor shall be used to bond the WF-68100-AD Series Converter-Charger to the vehicle frame.

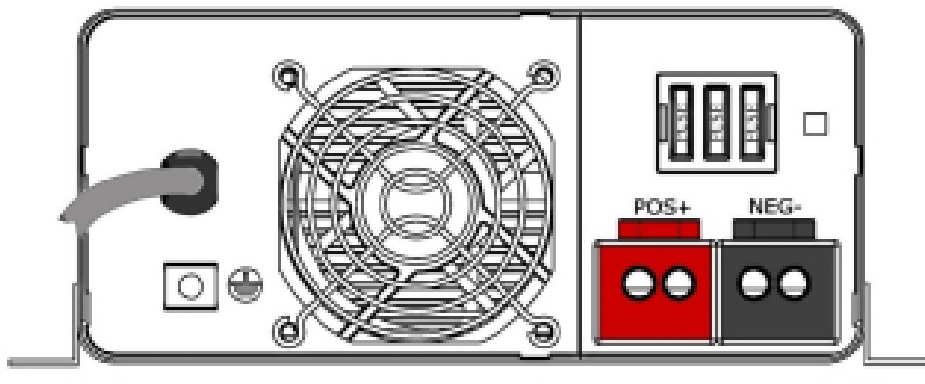

DC CONNECTIONS

Connect a red 2 AWG wire to the POS+ lug on the distribution center's fuse board. Make sure this lug is torqued properly. In a similar fashion, connect a black 2 AWG wire to the NEG- lug on the distribution center's fuse board.

AC CONNECTIONS

The WF-68100-AD Series Converter-Chargers receive power from the power cord located to the left of the rear panel fan. Due to the higher current required from the AC line to produce the high DC current output, a 20 Amp

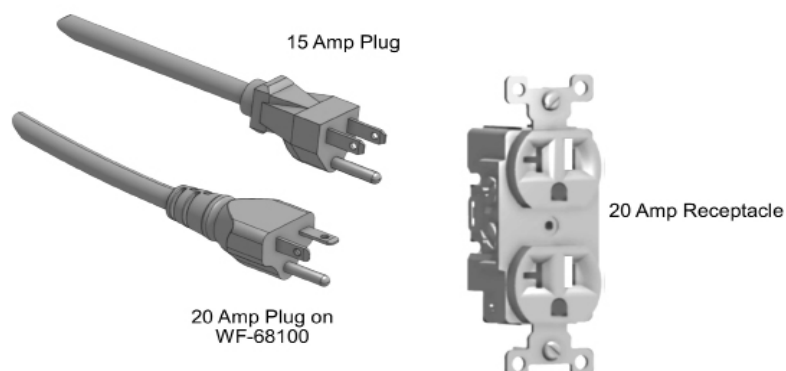

WF-68100-AD Converter Specification	
Model No.	WF-68100-AD
Converter Input Power	
Voltage:	105-130Vac
Frequency:	50Hz/60 Hz (47 ~ 63 Hz)
Power factor:	≥ 0.98
Max. input current @105Vac	16.5A
Max.Power	1700 watt
Converter Output Power	
Continuous power:	1360 watt
Rated DC Output Voltage	13.6V
Rated DC Current	100A
Charging Control	automatically controlled by micro-processor
Charging Mode:	3-stage intelligent charge / 2 stage intelligent charge
Intelligent charge mode	Absorption - Bulk and Storage / Absorption & Bulk
Battery Adaptability	LA/AGM / Lithium Ion
Absorption charge voltage	13.6V
Bulk charge voltage: (8 Hrs)	14.4V
Storage charge voltage	13.2V
Regulation	± 1% accuracy against input or load changes
Cooling Fan	Speed according to the DC load amperage
Efficiency:	> 80% (on 100% of load condition)
Protection	
Overload	current-limiting & shut down; auto-recovery upon normal load
Short-circuit	shut down & auto-recovery upon normal
Over-temperature	shut down & auto-recovery upon normal
Battery reverse polarity	protected by Fuse; same rated fuse replacement required
Display	
Green LED	Normal operation
Amber LED	Steady on - battery discharging; flickering - battery approaching low level
Red LED	All protection circuits except battery reverse protection
Button	Bulk mode (Press and hold the button for 5 seconds)
Dip switch	AGM/LEA-ACID or GEL-CELL
DC Distribution Board	
DC Battery Lugs: NEG-/POS+	Lugs accept 2 to 14 AWG wire; Lug screws are 5/16" Allen Head
Mechanical	
Dimension: W x H x D	10.39 x 3.94 x 13.58 inch / 264 x 100 x 345 mm
Weight:	10.25 lbs. / 4.65 kg
Environmental Condition	20 ~ 90% Non-condensing
Safety	UL458 certified; FCC Class B (in compliance)

CONSUMER LIMITED WARRANTY for WFCO Technologies Products

WFCO extends, to the original owner, a Two-Year Limited Product Warranty. This warranty is in effect from the date of original purchase for a period of two years. This limited warranty is extended specifically for and is limited to Recreational Vehicle application and is only valid within the continental United States, Alaska, Hawaii and the Provinces of Canada. WFCO warrants, to the owner, that its products are free from defects in material and workmanship under normal use and service based on its intended use and function. This warranty is limited to the repair or replacement, at WFCO's discretion, of any defective parts or defective assembly. Any implied warranties of merchantability or fitness for intended use are limited in duration unless applicable State Law provides otherwise. You may have other rights as specified by each individual state.

EXCLUSIONS AND LIMITATIONS

The OEM warranty specifically does not apply to the following:

- Any WFCO product that has been repaired or altered by an unauthorized person.
- Any damage caused by misuse, faulty installation, testing, negligence, accident or any WFCO product installed in a commercial vehicle.
- Any WFCO product, whose serial number has been defaced, altered or removed.
- Any WFCO product, whose installation has not been in accordance with the WFCO written instructions.
- Any consequential damages arising from the loss of use of the product including but not limited to inconvenience, loss of service, loss of revenue, loss or damage to personal property, cost of all services performed in removing or replacing the WFCO product. Specifications are subject to change without notice or obligation.
- Any WFCO Electronics products sold through unauthorized Internet sources. (Example: eBay) will be excluded from all warranty coverage offered by WFCO Technologies.

CONSUMER WARRANTY CLAIM PROCEDURE

Upon determination and validation by an authorized OEM dealer that a WFCO product has a defect, a Return Goods Authorization (RGA) number will be required before the product can be returned. The RGA number can be requested by completing the Warranty Information Fax Sheet and appropriate Troubleshooting Form found at www.wfcoelectronics.com. Once these forms have been completed, email the forms along with Proof of Purchase to warranty@wfcotech.com or fax the three documents to the Warranty Department at (574) 294-8698. After receipt of the forms, an RGA number will be issued. This number shall appear on all correspondence with warranty service. Upon validation of the warranty, WFCO shall replace the product with a like product. The RGA number shall be placed on the outside of the carton used to return the product for ease of identification.

Do not mark directly on the product. The product must be packaged properly to avoid further product damage which could cause a non-warrantable condition.

WARRANTY ASSISTANCE

The consumer may contact the selling Dealer or OEM for warranty assistance.

The consumer may also contact **WFCO Technologies at: (574) 294-8997 or Fax (574) 294-8698.**

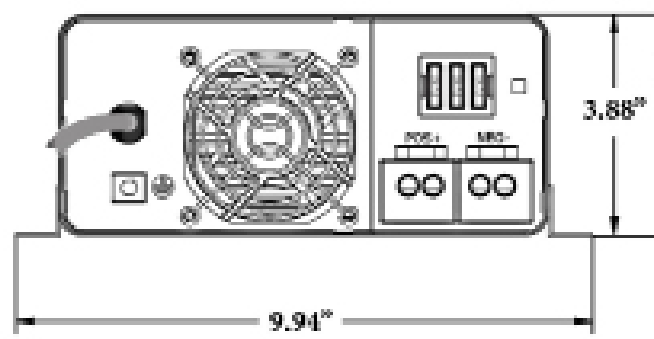
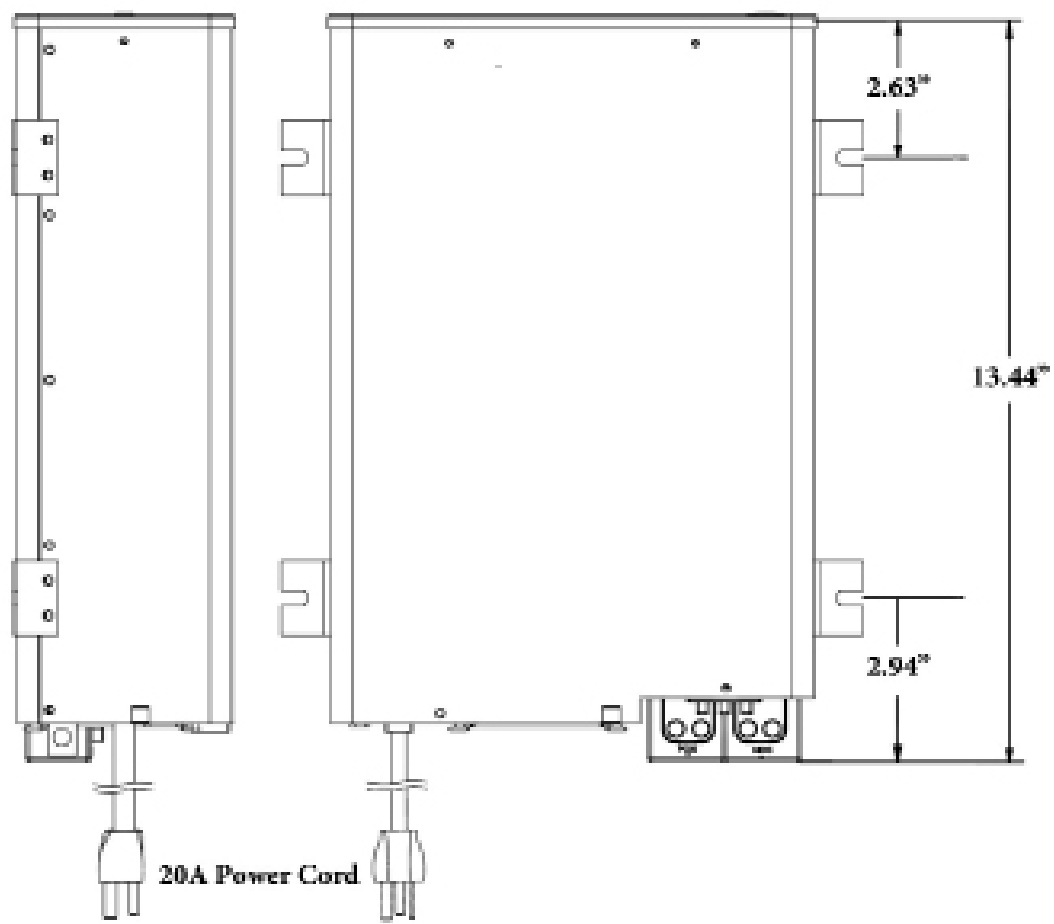

WFCO



TECHNOLOGIES

*Innovating the future of **RV POWER.***

2021 Aeroplex Drive, North
Elkhart, IN 46514
574-294-8997
www.wfcotech.com



EXPERT PRODUCT SUPPORT

Power Pros Technical Support
(574) 294-8997, Option 1
technicalsupport@wfcoelectronics.com

Warranty Information
Fax: (574) 294-8698
warranty@wfcoelectronics.com